

INTERCEPT® Blood System for Platelets –Dual Storage (DS) Processing Set (Semi-Integrated Set)

Rx Only

Caution: US Federal law restricts this device to sale by or on the order of a licensed healthcare practitioner

September 6, 2022

INTENDED USE

The INTERCEPT Blood System for Platelets is intended to be used for *ex vivo* preparation of pathogen-reduced Amicus apheresis platelet components suspended in 65% PAS-3/35% plasma, and Trima apheresis platelet components suspended in 100% plasma in order to reduce the risk of transfusion-transmitted infection (TTI), including sepsis, and as an alternative to gamma irradiation for prevention of transfusion-associated graft versus host disease (TA-GVHD).

DEVICE DESCRIPTION

The INTERCEPT Blood System for Platelets, DS Processing Set (Semi-Integrated Set), contains a sterile, non-pyrogenic, single-use, semi-integrated, fluid path platelet processing set (INT2540B) comprised of four key components (See **Table 1**) and an ultraviolet (UVA) illumination device (INT100) for the *ex vivo* preparation and storage of pathogen reduced apheresis platelet components. The INT100 is a microprocessor controlled device designed to deliver a controlled amount of UVA light, wavelength 320 to 400 nm, to up to two illumination containers simultaneously. The device is programmed to be able to control, deliver, record and store intensity and duration of light dose for each cycle.

Table 1 Components of the INTERCEPT Platelet DS Processing Set (INT2540B)

Component	Description
Amotosalen (S-59, psoralen derivative) solution container	17.5 mL, 3 mM amotosalen in 0.924% NaCl packaged in a 20 mL, flexible, heat-sealed plastic container, with light-protective sleeve
Illumination container	Heat-sealed, plastic bag
Compound Adsorption Device (CAD)	Immobilized beads (wafer) in mesh pouch
Platelet storage containers	Two platelet storage bags – 1300 mL storage capacity each

The operating principle for the INTERCEPT Blood System for Platelets (with Semi-Integrated Platelet Processing Set) is illustrated below (**Figure 1**). Platelets collected by apheresis in a container are sterile connected to the amotosalen solution container of the semi-integrated Platelet DS Processing Set [INT2540B]. The tubing between amotosalen solution container and illumination container are sterile connected to make an integrated sterile fluid path before the platelets flows through amotosalen container into the illumination container. The illumination container is placed into the INT100 illumination device for UVA treatment while being mixed with horizontal agitation. Inactivation of potential pathogen or leukocyte contaminants in platelet components is achieved through a photochemical treatment process. Amotosalen (S-59, psoralen derivative), a chemical capable of binding to nucleic acids is added to platelets. UVA illumination (320 – 400 nm wavelengths) of amotosalen-treated platelet

components induces covalent cross-linking of any nucleic acids to which amotosalen is bound; thereby, preventing further replication.¹ Treated platelets are then transferred to the CAD container to reduce the levels of residual amotosalen and free photoproducts. Finally, the platelet components are transferred through the in-line filter to the storage container for use or storage at 20-24°C with continuous agitation for up to 5 days from the time of collection.

Figure 1 INTERCEPT Blood System for Platelets (with Semi-Integrated Platelet Processing Set) and Treatment Process

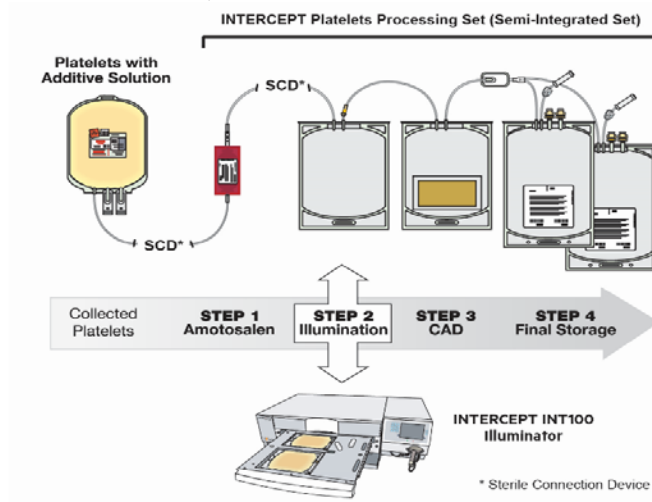

DEVICE PERFORMANCE

The INTERCEPT Blood System inactivates a broad spectrum of enveloped and non-enveloped viruses, Gram-positive and Gram-negative bacteria, spirochetes, parasites and leukocytes.²⁻²² There is no pathogen inactivation process that has been shown to eliminate all pathogens. Certain non-enveloped viruses (e.g., HAV, HEV, B19 and poliovirus) and *Bacillus cereus* spores have demonstrated resistance to the INTERCEPT process.

Table 2 Viral Reduction (Enveloped)^{4,14}

Pathogen	Platelets in PAS-3 Log ₁₀ Reduction (pfu/mL) ^a	Platelets in 100% Plasma Log ₁₀ Reduction(pfu/mL) ^a
HIV-1 IIIB, cell-associated	≥5.4	≥ 4.7
HIV-I IIIB, cell-free	≥5.6	d
HIV-1 Z84 (clinical isolate)	≥3.3	d
HIV-2 CLB-20 (clinical isolate)	≥2.4	d
DHBV ^b	≥4.8	≥4.3
BVDV ^c	≥4.1	>3.5
HTLV-I	4.7	d
HTLV-II	≥5.1	d
West Nile virus (WNV)	≥6.3	>6.3
Cytomegalovirus (CMV)	≥4.9	d
Pseudorabies virus (model for CMV)	d	≥4.2
Chikungunya virus (CHIKV)	≥5.7	>6.5
Dengue virus (DENV)	≥4.3	3.6
Influenza A virus	≥5.9	d

^a Based on input titer and post-treatment titer in 1 mL, data obtained in platelets in PAS-3 or plasma components unless otherwise noted

^b DHBV model virus for HBV

^c BVDV model virus for HCV

^d = Not tested

Table 3 Viral Reduction (Non-Enveloped)^{4,17}

Pathogen	Platelets in PAS-3 Log ₁₀ Reduction (pfu/mL) ^a	Platelets in 100% Plasma Log ₁₀ Reduction (pfu/mL) ^a
Calicivirus (model non-enveloped virus)	2.1	0.9
Adenovirus	≥4.9	≥5.3
Blue tongue virus (model non-enveloped virus)	5.2	4.4

^a Based on input titer and post-treatment titer in 1 mL, data obtained in platelet components in PAS-3 or plasma components unless otherwise noted

Table 4 Bacterial Reduction^{15,16}

Pathogen	Platelets in PAS-3 Log ₁₀ Reduction (cfu/mL) ^a	Platelets in 100% Plasma Log ₁₀ Reduction (cfu/mL) ^a
Gram-Negative Bacteria		
<i>Klebsiella pneumoniae</i>	>6.2	>6.2
<i>Escherichia coli</i>	≥6.3	>5.9
<i>Serratia marcescens</i>	≥6.7 ^b	>7.1
<i>Pseudomonas aeruginosa</i>	≥6.7	≥6.7
<i>Salmonella choleraesuis</i>	6.2	>5.9
<i>Enterobacter cloacae</i>	>6.6	>6.8
<i>Yersinia enterocolitica</i>	≥5.9	>6.3
Gram-Positive Bacteria		
<i>Staphylococcus epidermidis</i>	≥6.4	>6.5
<i>Staphylococcus aureus</i>	≥6.6	≥6.5
<i>Listeria monocytogenes</i>	≥6.3 ^b	>6.6
<i>Corynebacterium minutissimum</i>	≥5.3	>6.4
<i>Streptococcus pyogenes</i>	≥6.8 ^b	>6.1
<i>Bacillus cereus</i> (vegetative)	≥5.5	≥5.6
<i>Bacillus cereus</i> (spore forming)	3.7 ^b	^c
Anaerobic Gram-Positive Bacteria and Spirochete Bacteria		
<i>Bifidobacterium adolescentis</i>	≥6.0	^c
<i>Propionibacterium acnes</i>	≥6.5	>6.7
<i>Clostridium perfringens</i> (vegetative)	≥6.5	>6.0
<i>Lactobacillus species</i>	≥6.4	>6.1
<i>Treponema pallidum</i>	≥6.4	>6.3
<i>Borrelia burgdorferi</i>	≥6.8	>4.1

^a Based on input titer and post-treatment titer in 1 mL, data obtained in platelet components in PAS-3 or plasma components unless otherwise noted

^b Based on culture of full platelet unit (300 mL)

^c = Not tested

Table 5 Protozoa Reduction¹⁹⁻²¹

Pathogen	Platelets in PAS-3 Log ₁₀ Reduction (pfu or cfu/mL) ^a	Platelets in 100% Plasma Log ₁₀ Reduction (pfu or cfu/mL) ^a
<i>Plasmodium falciparum</i>	≥6.6	>6.5
<i>Babesia microti</i>	≥4.9	>4.5
<i>Trypanosoma cruzi</i>	≥7.8	>8.4
<i>Leishmania mexicana</i> (metacyclic promastigote stage)	≥5.0	^b

^a Based on input titer and post-treatment titer in 1 mL, data obtained in platelet components in PAS-3 or plasma components unless otherwise noted

^b = Not tested

The INTERCEPT process for platelets reduces a broad spectrum of bacteria by $> 4 \log_{10}$ (**Table 4**) to lower the risk of microbial contamination of blood components.²¹ Bacterial spores are resistant to inactivation by the INTERCEPT Blood System for platelets.

Contaminating T cell proliferative activity is reduced by the INTERCEPT treatment, for the prevention of transfusion-associated graft versus host disease (TA-GVHD).²²⁻²⁷ Using a limiting dilution assay (LDA), the INTERCEPT Blood System exhibited a $4 \log_{10}$ reduction of viable T-cells. Using a DNA modification assay, platelets processed with the INTERCEPT Blood System demonstrated an average of one amotosalen adduct every 83 base pairs in leukocytes.

In vitro Characterization of Platelet Components Processed with the INTERCEPT Blood System.

In vitro platelet function characteristics were evaluated in prospective, randomized, paired, controlled, *in vitro* studies in healthy subjects of INTERCEPT apheresis platelet components compared to unprocessed (Control) platelet components. Each study subject donated a single- or double-apheresis platelet component, during each of the two donation periods. Components from the platelet donations were randomized to produce INTERCEPT processed platelet components or control platelet components. *In vitro* platelet function of the platelet components was evaluated on day 5 after apheresis donation. The physical and metabolic characteristics for evaluation included: component volume platelet count, platelet volume (MPV), pH_{22-c}, pO₂, pCO₂, HCO₃, morphology, supernatant LDH activity, P-selectin, total ATP, extent of shape change, hypotonic shock response, supernatant glucose, and supernatant lactate.

1. Storage in 65% PAS-3/35% Plasma:

72 single-dose and double-dose Amicus platelet collections containing $2.9 - 8.0 \times 10^{11}$ platelets in PAS-3 treated with the INTERCEPT Blood System for platelets and stored for 5 days retained presumptively therapeutically effective platelet doses (mean of 3.8×10^{11} platelets and lower bound of the 95% confidence interval (CI) for the proportion of INTERCEPT processed platelet components retaining $> 3.0 \times 10^{11}$ platelets was 82.5%) with an average dose recovery after INTERCEPT treatment of 87.3% (95% CI: 85.7% to 89.0%), and with retention of adequate *in vitro* metabolic and functional properties (**Table 6**).

Table 6 In Vitro Platelet Function Characteristics of INTERCEPT (I) and Control (C) Platelets in PAS-3 After 5 Days of Storage (Mean +/- SD (median) [range]; n=72)

	INTERCEPT	Control	95% CI for Treatment Difference (I-C)	INTERCEPT within $\pm 20\%$ of Control, # / N (%) [†]
Platelet Component Characteristics				
Component volume (mL)	288 \pm 55 (292) [158 – 399]	295 \pm 52 (301) [188 – 402]	-19 to 6	62/72 (86.1%)
Platelet count ($\times 10^3/\mu\text{l}$)	1356 \pm 243 (1350) [907 – 1953]	1409 \pm 271 (1409) [800 – 2019]	-105 to -3*	60/72 (83.3%)
Platelet dose ($\times 10^{11}$ cells/unit)	3.8 \pm 0.8 (3.7) [2.7 – 5.9]	4.1 \pm 0.7 (4.1) [2.5 – 5.7]	-0.4 to -0.0*	65/72 (90.3%) ^{††}
MPV (fL)	7.7 \pm 0.8 (7.6) ^b [6.1 – 9.3]	7.7 \pm 0.9 (7.7) ^c [6.0 – 9.9]	-0.1 to 0.2 ^{c,*}	65/65 (100%)

	INTERCEPT	Control	95% CI for Treatment Difference (I-C)	INTERCEPT within $\pm 20\%$ of Control, # / N (%)[†]
Indices of Platelet Metabolism				
pH at 22°C	7.0 \pm 0.1 (7.0) [6.8 – 7.3]	7.0 \pm 0.1 (7.0) [6.6 – 7.3]	-0.0 to 0.1	72/72 (100%) ^{†††}
pO₂ (mm Hg)	134 \pm 22 (136) ^b [69 - 181]	112 \pm 23 (109) ^d [66 - 171]	15 to 26 ^{c,*}	33/65 (50.8%)
pCO₂ (mm Hg)	20 \pm 4 (21) ^b [11 – 29]	27 \pm 4 (27) ^d [14 – 34]	-8 to -6 ^{c,*}	19/65 (29.2%)
HCO₃⁻ (mmol/L)	3.4 \pm 1.0 (3.2) ^e [1.0 – 5.5]	4.3 \pm 1.3 (4.0) ^c [2.0 – 7.0]	-1.4 to -0.6 ^{e,*}	12/62 (19.4%)
Extracellular glucose (mmol/L)	1.8 \pm 1.1 (1.9) [0.1 – 4.9]	1.9 \pm 4.2 (1.3) [0.1 – 35.0]	-1.1 to 0.9	23/72 (31.9%)
Extracellular lactate (mmol/L)	10.1 \pm 2.1 (10.0) [6.5 – 15.2]	12.0 \pm 2.9 (12.1) [6.9 – 17.7]	-2.5 to -1.3 [*]	40/72 (55.6%)
Total ATP (nmol/10⁸ Plts)	3.9 \pm 1.2 (3.5) [1.6 – 7.1]	3.4 \pm 1.3 (3.4) [1.1 – 6.8]	0.1 to 0.8 [*]	38/72 (52.8%)
Indices Correlating with In Vivo Recovery, Survival and Function				
Morphology Score	280 \pm 27 (279) [205 – 324]	266 \pm 29 (270) [159 – 329]	7 to 22 [*]	64/72 (88.9%)
Extent of Shape Change (%)	17.8 \pm 6.4 (17.2) [7.3 – 35.0]	15.7 \pm 5.9 (16.0) [1.7 – 31.3]	0.6 to 3.6 [*]	32/72 (44.4%)
Hypotonic Shock Response (%)	41.1 \pm 9.7 (41.9) [13.5 – 61.7]	39.2 \pm 12.7 (41.5) [14.6 – 65.9]	-1.5 to 5.3	35/72 (48.6%)
Indices of Granular and Cytoplasmic Content Retention				
LDH activity (IU/L)	144 \pm 57 (129) ^f [72 – 334]	114 \pm 46 (108) ^b [43 – 282]	17 to 43 ^{h,*}	29/72 (40.3%)
LDH (IU/10¹² Plts)	110 \pm 53 (95) ^f [52 – 297]	83 \pm 36 (71) ^b [34 – 252]	16 to 39 ^{h,*}	25/72 (34.7%)
Baseline Adjusted Platelet Lysis (%)^a	3.2 \pm 2.0 (2.7) ^f [0.9 – 10.2]	2.0 \pm 1.2 (1.7) ^b [0.4 – 7.1]	0.7 to 1.7 ^{h,*}	19/64 (29.7%)
P-selectin (%)	39.1 \pm 12.0 (39.0) [16.5 – 61.6]	33.6 \pm 15.8 (29.0) [10.6 – 68.9]	2.4, 8.7 [*]	19/72 (26.4%)

^a Lysis value adjusted to remove lysis due to collection injury; ^b N=67, ^c N=65, ^d N=70, ^e N=63, ^f N=69, ^g N=62, ^h N=64

*Statistically significant difference (p<0.05) between INTERCEPT and Control

[†]72 evaluable pairs were analyzed for all assays except MPV, pO₂, pCO₂, HCO₃ and baseline adjusted lysis

^{††} The analysis criterion is $\geq 3.0 \times 10^{11}$ cells/unit for platelet dose.

^{†††} The analysis criterion is ≥ 6.2 for pH_{22°C}.

2. Storage in 100% Plasma:

68 single-dose and double-dose Trima platelet collections suspended in 100% plasma containing $3.2\text{--}7.9 \times 10^{11}$ platelets in 100% plasma treated with the INTERCEPT Blood System for platelets and stored for 5 days showed a mean platelet dose of 3.9×10^{11} (the lower bound of the 95% CI for the proportion of INTERCEPT processed platelet components retaining $>3.0 \times 10^{11}$ platelets/component was 87.0%) with an average dose recovery after INTERCEPT treatment of 84.9%, (95% CI: 83.8% to 86.0%), and with retention of adequate *in vitro* metabolic and functional properties (Table 7).

Table 7 *In Vitro* Platelet Function Characteristics of INTERCEPT (I) and Control (C) Platelets in 100% Plasma After 5 Days of Storage (Mean \pm SD (median) [range]; n=68)

	INTERCEPT	Control	95% CI for Treatment Difference (I-C)	INTERCEPT within $\pm 20\%$ of Control, # / N (%) [†]
Platelet Component Characteristics				
Component volume (mL)	306 \pm 61 (327) [183 – 396]	294 \pm 71 (321) [183 – 413]	-5 to 28	58/68 (85.3%)
Platelet count ($\times 10^3/\mu\text{L}$)	1286 \pm 254 (1270) [848 – 1849]	1408 \pm 221 (1384) [816 – 1884]	-157 to -86*	57/68 (83.8%)
Platelet dose ($\times 10^{11}$ cells/unit)	3.9 \pm 0.9 (3.7) [2.6 – 5.9]	4.0 \pm 0.8 (4.1) [2.8 – 5.6]	-0.4 to 0.1	64/68 (94.1%) ^{††}
MPV (fL)	7.3 \pm 0.7 (7.3) [5.8 - 9.0]	7.5 \pm 1.0 (7.3) [6.1 - 11.0]	-0.3 to -0.0*	68/68 (100%)
Indices of Platelet Metabolism				
pH at 22°C	7.4 \pm 0.2 (7.4) [6.9 – 7.9]	7.5 \pm 0.3 (7.5) [6.0 – 7.9]	-0.1 to +0.0	68/68 (100%) ^{†††}
pO ₂ (mm Hg)	138 \pm 18 (141) [44 - 172]	126 \pm 22 (130) [37 - 190]	5 to 19*	46/68 (67.6%)
pCO ₂ (mm Hg)	27.2 \pm 4.3 (26.5) [20.0 – 36.9]	28.2 \pm 5.3 (27.6) [17.0 – 47.9]	-2.1 to 0.1	58/68 (85.3%)
HCO ₃ ⁻ (mmol/L)	7.9 \pm 2.0 (7.7) [3.0 - 12.3]	9.9 \pm 2.4 (10.3) ^c [2.0 - 13.6]	-2.6 to -1.5 ^{c,*}	27/66 (40.9%)
Extracellular glucose (mmol/L)	13.0 \pm 2.9 (12.6) [8.7 – 26.3]	14.3 \pm 3.6 (14.8) [2.9 – 29.7]	-1.9 to -0.6*	51/68 (75.0%)
Extracellular lactate (mmol/L)	9.8 \pm 2.7 (10.1) [3.2 - 15.7]	9.8 \pm 4.6 (8.9) [3.5 - 33.7]	-1.0 to 1.0	30/68 (44.1%)
Total ATP (nmol/10 ⁸ Plts)	4.1 \pm 1.1 (4.0) [1.7 – 7.9]	4.2 \pm 1.2 (4.3) [1.3 – 6.5]	-0.4 to 0.3	39/68 (57.4%)
Indices Correlating with <i>In Vivo</i> Recovery to Survival and Function				
Morphology Score	285 \pm 32 (283) [212 – 349]	278 \pm 39 (269) [178 – 352]	-1 to 16	60/68 (88.2%)
Extent of Shape Change (%)	20.8 \pm 4.6 (20.0) [12.8 - 31.6]	23.1 \pm 5.0 (23.4) [0.7 - 33.5]	-3.5 to -1.1*	40/68 (58.8%)
Hypotonic Shock Response (%)	57.1 \pm 12.3 (57.4) [33.7 - 81.9]	50.5 \pm 11.6 (51.1) [0.0 - 77.0]	3.0 to 10.2*	39/68 (57.4%)

	INTERCEPT	Control	95% CI for Treatment Difference (I-C)	INTERCEPT within ± 20% of Control, # / N (%)[†]
Indices of Granular and Cytoplasmic Content Retention				
LDH activity (IU/L)	229 ±70 (208) [133 – 445]	162 ±32 (158) [108 – 282]	51 to 84*	18/68 (26.5%)
LDH (IU/10¹² Plts)	184 ±61 (177) [89 - 351]	117 ±26 (116) [69 - 185]	52.9 to 80.5	12/68 (17.6%)
Baseline Adjusted Platelet Lysis (%)^a	3.7 ±2.3 (3.1) ^b [0.6 - 9.0]	1.0 ±0.8 (0.9) ^d [0.0 - 4.3]	2.1 to 3.3 ^{d,*}	7/65 (10.8%)
P-selectin (%)	21.4 ±8.9 (19.8) [8.4 – 47.3]	15.8 ±11.9 (12.6) [5.0 – 94.9]	2.2 to 9.0*	18/68 (26.5%)

^a Lysis value adjusted to remove lysis due to collection injury; ^bN=67; ^cN=66; ^dN=65

*Statistically significant difference (p<0.05) between INTERCEPT and Control

[†]68 evaluable pairs were analyzed for all assays except HCO₃ and baseline adjusted lysis

^{††} The analysis criterion is $\geq 3.0 \times 10^{11}$ cells/unit for platelet dose.

^{†††} The analysis criterion is ≥ 6.2 for pH_{22°C}.

CONTRAINDICATIONS

- Contraindicated for preparation of platelet components intended for patients with a history of hypersensitivity reaction to amotosalen or other psoralens.
- Contraindicated for preparation of platelet components intended for neonatal patients treated with phototherapy devices that emit a peak energy wavelength less than 425 nm, or have a lower bound of the emission bandwidth <375 nm, due to the potential for erythema resulting from interaction between ultraviolet light and amotosalen.

Note: Information about these contraindications needs to be included in the labeling provided with transfusable platelets prepared using the INTERCEPT Blood System for platelets.

WARNINGS AND PRECAUTIONS

- Only INTERCEPT Processing Sets for platelets are approved for use with the INTERCEPT Blood System. Use only the INTERCEPT INT100 Illuminator for UVA illumination of amotosalen-treated platelet components. No other source of UVA light may be used. Please refer to the Operator's Manual for the INT100 Illuminator. Discard any platelet components not exposed to the complete INT100 illumination process.
- Tubing components and container ports of the INTERCEPT Blood System contain polyvinyl chloride (PVC). Di(2-ethylhexyl)phthalate (DEHP) is known to be released from PVC medical devices, and increased leaching can occur with extended storage or increased surface area contact. Blood components will be in contact with PVC for a brief period of time (approx. 15 minutes) during processing. The risks associated with DEHP released into the blood components must be weighed against the benefits of therapeutic transfusion.

Note: Information about these Warnings and Precautions needs to be included in the labeling provided with transfusable platelets prepared using the INTERCEPT Blood System for Platelets.

INSTRUCTIONS FOR USE

Initial Setup

Equipment Provided: One (1) INT2540B Dual Storage Processing Set (Semi-Integrated Set)

Equipment Available Separately: INTERCEPT INT100 Illuminator

Equipment Required But Not Provided: Sterile Connecting Device (SCD), Tube Sealer, Flatbed Agitator, Manual Tube Clamp (e.g., Hemostat)

- **INTERCEPT Processing Sets for platelets are for single use only. Do not reuse sets or components of sets.**
- This process is designed to be a functionally closed system. Treatment with INTERCEPT Blood System does not replace applicable standards for processing in open and closed systems.

Blood Collection

Leukocyte reduced platelets collected by apheresis are used. Refer to **Table 8** for specifications of the platelet products which are used with this processing set.

Table 8 Platelet Input and Processing Specifications for INTERCEPT Dual Storage Processing Set (Semi-Integrated Set)

	Platelets in PAS-3		Platelets in 100% Plasma	
Platelet Input Specifications				
Platelet Source	Amicus Apheresis	Amicus Apheresis	Trima Apheresis	Trima Apheresis
Suspension Medium	PAS-3 and plasma (32-47%)	PAS-3 and plasma (32-47%)	100% Plasma	100% Plasma
Platelet Input Volume	300 – 390 mL	375 – 420 mL	300 – 390 mL	375 – 420 mL
Platelet Dose	$3.0 - 6.0 \times 10^{11}$	$4.0 - 8.0 \times 10^{11}$	$3.0 - 5.2 \times 10^{11}$	$5.3 - 7.9 \times 10^{11}$
Platelet Count	$0.8 - 2.0 \times 10^9/\text{mL}$	$0.95 - 2.1 \times 10^9/\text{mL}$	$0.8 - 1.7 \times 10^9/\text{mL}$	$1.3 - 2.1 \times 10^9/\text{mL}$
RBC Content	$< 4 \times 10^6 \text{ RBC}/\text{mL}$	$< 4 \times 10^6 \text{ RBC}/\text{mL}$	$< 4 \times 10^6 \text{ RBC}/\text{mL}$	$< 4 \times 10^6 \text{ RBC}/\text{mL}$
Processing Specifications				
Number of Storage Bags	1	1 or 2	1	2
CAD Time	6-16 Hrs	6-16 Hrs	12-24 Hrs	12-24 Hrs
Maximum Storage	5 Days	5 Days	5 Days	5 Days

Platelet Processing

Platelets must be exposed to UVA light within 24 hours after collection.

Refer to **Figure 2** for labeling and identification of set components.

Figure 2 INTERCEPT Dual Storage Processing Set (Semi-Integrated Set)

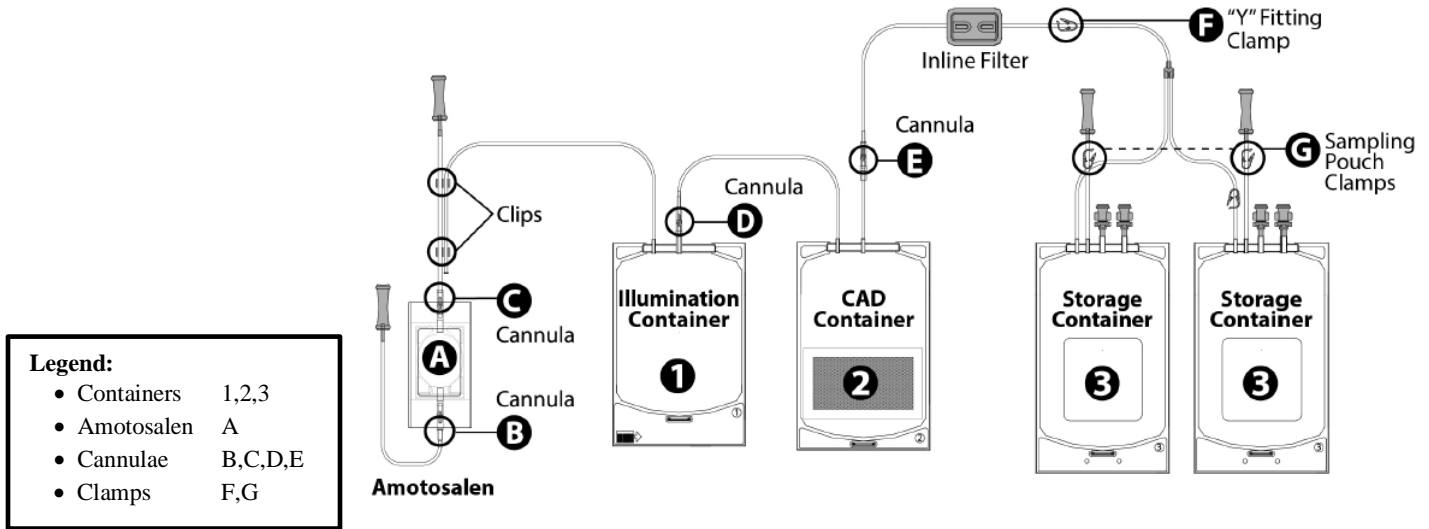

I. Amotosalen Addition

NOTE: Amotosalen in contact with skin may result in photosensitization in the presence of ultraviolet light. If skin exposure occurs, flush exposed skin with water.

1. Remove set from package. Unwrap only illumination container (1) from organizer.
2. Weld tubing from amotosalen container (A) to illumination container (1) tubing using SCD and weld tubing from platelet collection container to amotosalen container (A) tubing using SCD. (Note: these two actions can be taken in either order).
3. Label storage container (3) using appropriate donation identification.
4. Hang platelet collection container and break cannula (C) below amotosalen container (A) to let amotosalen flow into illumination container (1); visually verify amotosalen is present.
5. Break cannula (B) above amotosalen container (A) to let platelets flow through amotosalen container (A) into illumination container (1).
6. Ensure the platelets drain completely from initial platelet collection container into illumination container (1) by expressing air from the illumination container (1) into amotosalen container (A).
7. When air is removed and platelets have fully drained back through tubing into illumination container (1), manually clamp tubing above illumination container. Mix illumination container thoroughly by gentle agitation to ensure complete mixing of amotosalen and platelets (Figure 3).

Figure 3 Gently Agitate the Filled Illumination Container

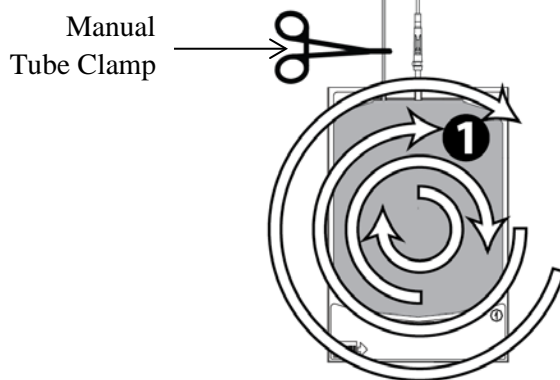

8. Open manual tube clamp and express a small amount of platelet and amotosalen mixture into tubing, filling about 1.5 inches of tubing. Close manual clamp.
9. Seal tubing between illumination container (**1**) and amotosalen container (**A**) within the 1.5 inches of tubing (See **Figure 4**).

Figure 4 Heat Seal Filled Tubing Within 1.5 Inches

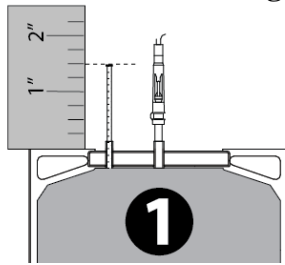

10. Remove and discard empty platelet collection container, amotosalen container (**A**) and excess tubing.

II. Illumination

Refer to INT100 Illuminator Operator's Manual for detailed instructions.

NOTE: The inactivation process requires unimpeded light transmission through tray and illumination container. The illumination container and tubing must be within the large compartment of the illuminator tray. Tray must be clean and free from labels or other material (see **Figure 5**). Illumination container should lay flat in order to ensure complete illumination.

NOTE: During illumination, tubing must be held within large compartment of illumination tray (see below).

Figure 5 Proper Way to Load Processing Set Into the Illuminator Tray

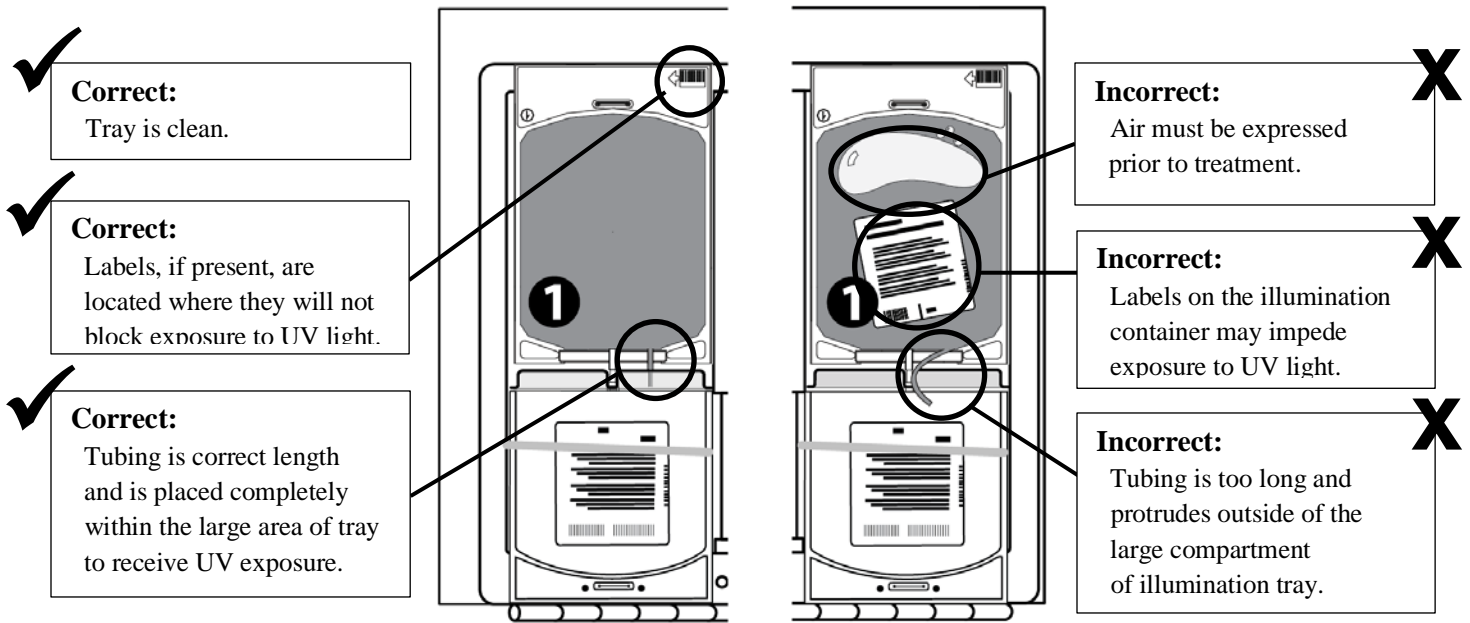

III. Agitation with Compound Adsorption Device (CAD)

Do not fold or bend CAD.

1. Unwrap set from organizer.
2. Hang platelets in illumination container (❶), break cannula (❷) and allow platelets to flow into CAD container (❸).
3. Express air from CAD container (❸) into illumination container (❶). Do not fold or bend CAD.
4. Seal tubing close to inlet port of CAD container (❸).
5. Remove and discard empty illumination container (❶) and excess tubing.
6. Place CAD container (❸) flat on flatbed agitator with attached storage containers for 6-16 hours for Amicus platelets in PAS-3 or 12-24 hours for Trima platelets in 100% plasma. Agitation rate must be at least 60 RPM. Do not stop the process before the minimum time and do not extend the process beyond the maximum allowable time.
7. Do not fold or place storage container (❹), in line filter, or any tubing under CAD container (❸) during agitation.

IV. Transfer to Storage Container

1. Remove platelets from agitator and hang platelets in CAD container (❸).
2. Expel air from platelet sampling pouch into storage container and close clamps (❺).
3. Break cannula (❻) at outlet of CAD container (❸) and allow platelets to flow into each of the two storage containers (❻).
4. Express air from storage containers (❻) into CAD container (❸) and close clamp (❻) above the Y fitting.
5. Redistribute volume between storage containers (❻) as needed.
Note: Steps 4 and 5 may be performed in the reverse order.
6. Ensure appropriate donor identification is attached to each filled platelet storage container (❻).
7. Seal tubing close to the outlet of the Y fitting as needed for each therapeutic dose of platelets.
 - For Amicus platelets in PAS-3:
 - Components with input doses $<6.1 \times 10^{11}$ should be stored in one container.
 - Components with input doses $\geq 6.1 \times 10^{11}$ and output doses that do not enable splitting into two therapeutic doses of $\geq 3.0 \times 10^{11}$ each should be stored in two connected containers.
 - Components with input doses $\geq 6.1 \times 10^{11}$ and output doses that enable splitting into two therapeutic doses of $\geq 3.0 \times 10^{11}$ each should be stored in two separate containers.
 - For Trima platelets in 100% plasma:
 - Components with input doses $<5.3 \times 10^{11}$ should be stored in one container.
 - Components with input doses $\geq 5.3 \times 10^{11}$ and output doses that do not enable splitting into two therapeutic doses of $\geq 3.0 \times 10^{11}$ each should be stored in two connected containers.
 - Components with input doses $\geq 5.3 \times 10^{11}$ and output doses that enable splitting into two therapeutic doses of $\geq 3.0 \times 10^{11}$ each should be stored in two separate containers.
8. Remove and discard empty CAD container (❸) and tubing. Place platelets on platelet agitator.

The INTERCEPT treatment process is now complete.

V. Sampling Platelet Product (optional)

1. Mix INTERCEPT treated platelets by gently agitating platelet storage container.
2. Open clamp () to platelet sampling pouch and squeeze several times.
3. Allow sampling pouch to fill with platelets. Seal tubing.
4. Remove sample pouch.
5. Transfer sample to appropriate laboratory tube immediately.

STORAGE AND HANDLING

Processing Sets

- Do not use if tamper-evident package has been opened, signs of deterioration are visible, fluid path closures are loose or not intact, cannulae are broken or if there is no fluid in the amotosalen solution container.
- Protect the processing set package and tubing from sharp objects. Discard platelet product if there is a leak in the set during processing.
- Keep processing sets in the light-protective, aluminum foil pouch until time of use. Protect from direct sunlight and strong UVA light source.
- Do not store processing set above 25°C.
- Do not vent.
- Do not freeze.
- Unused processing sets may be stored for up to 20 days at room temperature (18 – 25°C) in the open aluminum foil pouch by folding and securing the open end of the pouch. Record the “Date Opened” and “Use By” date on the foil pouch label in the space provided. The processing sets removed from the aluminum foil pouch must be used within 8 hours.

Platelet Components

- Platelet components processed with the INTERCEPT Blood System must be stored in the platelet storage container provided in the INT2540B processing sets.
- Processed platelet components may be stored at 20-24°C with continuous agitation for up to 5 days from the day of collection.

NONCLINICAL TOXICOLOGY

Nonclinical studies were conducted in mice, rats and dogs to evaluate the potential toxicity of single and repeated exposures to amotosalen, the synthetic psoralen derivative used in the INTERCEPT process to cross-link DNA and RNA. A single, intravenous injection of amotosalen alone resulted in mortality in rats at doses equal to or greater than 100,000-fold the anticipated human clinical exposure from a single transfusion of INTERCEPT processed platelets as compared on a dose per kilogram body weight basis. Lower doses of amotosalen (12,000- or 60,000-fold greater than the anticipated human clinical exposure in dogs and rats, respectively) were not lethal, and resulted in transient clinical signs of toxicity (i.e. piloerection, inactivity, hunched posture and abnormal breathing in rats, and excessive salivation, swelling of the muzzle and eyelids, and non-lethal cardiac arrhythmias in dogs). No target organ toxicities were noted at necropsy.²⁹

Animal experiments with amotosalen provided no indication of an increased toxicological risk for the use of platelets treated using the INTERCEPT Blood System. Repeat-dose toxicity studies in rats and dogs dosed by daily intravenous injection for 7 to 28 days with amotosalen, at doses with at least 30,000- and 10,000-fold, respectively, the anticipated clinical exposure from transfusion of 300 mL of INTERCEPT Blood System-processed platelets showed no evidence of toxicity.^{29, 30} Transient, minor changes in hematology profiles with no correlating histopathology findings or major organ toxicities were reported in dogs dosed 3 times weekly for 13 weeks with autologous platelets processed with the INTERCEPT Blood System, at a cumulative amotosalen exposure of approximately 115-fold the anticipated clinical exposure following a single transfusion of 300 mL of INTERCEPT processed platelets.

Amotosalen was rapidly eliminated in mice and rats with an initial plasma $t_{1/2}$ of less than 1 hour. There was no evidence of amotosalen accumulation after repeated exposures over periods as long as 13 weeks. The primary route of excretion of amotosalen and its photoproducts was fecal.²⁹

No effects on fertility parameters were noted in male or female rats dosed with amotosalen. In studies evaluating the effects of amotosalen dosing of pregnant rats or rabbits on embryo-fetal or peri-postnatal development in pregnant rats and rabbits, and in one study dosing neonatal rats with amotosalen, there was no evidence of teratogenicity, or other reproductive or developmental toxicities.³¹

No evidence of genotoxicity or mutagenicity was observed in the *in vitro* or *in vivo* mutagenicity studies of amotosalen. In transgenic mice heterozygous for the p53 tumor suppressor gene, there was no evidence of carcinogenicity after repeated three times weekly dosing with amotosalen for 6 months at cumulative weekly doses approximately 1200 times the daily human exposure from a single 300 mL transfusion of INTERCEPT Blood System-treated platelets.³²

CLINICAL STUDIES

The safety and effectiveness of INTERCEPT processed platelets were investigated in 10 controlled clinical studies.³³⁻⁴² A total of 844 study subjects received INTERCEPT processed platelets in these clinical studies.

Three trials were conducted in healthy volunteers to measure the viability of INTERCEPT processed platelets and the clearance of residual amotosalen.^{33,34} Three studies utilized small doses (15-20 mL) of radiolabelled platelets; and in one study a full therapeutic dose (300 mL) was administered. All platelet components (PCs) were apheresis collections.

The primary endpoint of the three studies with radiolabelled platelets was post-transfusion viability of autologous INTERCEPT processed platelets after 5 days of storage. Autologous platelets from healthy donors prepared with the prototype IBS System (no amotosalen reduction) and stored for 5 days before transfusion demonstrated mean post transfusion recovery 77.8 % of untreated PCs, and mean life span 74.5 % of untreated PCs. Similarly, autologous platelets from healthy donors prepared with the prototype IBS System (with amotosalen reduction) and stored for 5 days before transfusion demonstrated mean post transfusion recovery 84.5 % of untreated PCs and life span 80 % of untreated PCs.

The primary endpoint of the full dose transfusion of INTERCEPT processed platelets was clearance of residual amotosalen. Peak post transfusion amotosalen levels were < 1 ng/ml with clearance kinetics of residual amotosalen median terminal (T_{50} = 6.5 hr) with acceptable tolerability after rapid transfusion of a therapeutic platelet dose.³⁴

No clinically relevant adverse events were observed in healthy subjects exposed to small volumes of autologous radiolabeled platelets or after transfusion of 300 mL of autologous INTERCEPT treated platelet components.

A randomized, controlled, double blind, parallel-group study to compare the therapeutic efficacy and safety of INTERCEPT processed apheresis platelet components to conventional apheresis platelet components using a non-inferiority design was conducted in patients requiring 1 or more platelet transfusions to support hypoplastic thrombocytopenia.^{28, 35, 65} The study was designed to assess the proportion of patients with Grade 2 bleeding during up to 28 days of platelet transfusion support. A total of 645 patients (318 Test, 327 Reference) received a total of 4719 platelet transfusions (2678 Test, 2041 Reference). There were 186/318 (58.5%) patients in the Test group and 188/327 (57.5%) patients in the Reference group with Grade 2 bleeding. The test result met the efficacy success criteria of the non-inferiority margin of 12.5%. Differences in mean number of transfusions, average interval between transfusions, rates of refractoriness, mean days with Grade 2 bleeding and mean count increment and corrected count increment at 1 and 24 hours were all statistically significantly different favoring the control group. The targeted platelet transfusion dose was 3.7×10^{11} . Sixty percent of the subjects in the INTERCEPT processed platelet group received a platelet dose of less than 3×10^{11} compared to 36% in the control group. Additionally, subjects in the INTERCEPT processed platelet group received off-protocol transfusions (32 vs. 15%) more often than the control group because of protocol violations. In order to assess whether the platelet dose could have impacted all these efficacy endpoint outcomes, a post-hoc analyses on three different subsets of subjects: subjects who received transfusions dose of platelets $\geq 3 \times 10^{11}$, subjects who received off-protocol transfusions, and subsets who received transfusions dose of platelets $\geq 3 \times 10^{11}$ without any off-protocol transfusions was conducted. In all the three subsets, a statistically significant difference was no longer seen in mean days with Grade 2 bleeding and in the mean number of platelet transfusions. Adjusting the platelet dose per unit to $\geq 3 \times 10^{11}$ may overcome the differences of these outcomes seen in the original study analysis.³⁵

There were no differences between treatment groups in the frequencies of Grade 3 and Grade 4 adverse events, serious adverse events, or mortality. Statistically significant differences for increased incidence of four adverse events of Grade 3 and Grade 4 severity were observed among recipients of INTERCEPT processed platelets. These included: pneumonitis not otherwise specified (5 versus 0); ARDS (5 versus 0); hypocalcemia (21 versus 8); and syncope (6 versus 0). A subsequent blinded, retrospective analysis of patients with clinically significant pulmonary adverse events (n = 148) demonstrated no significant increase in incidence of acute lung injury (ALI), including ARDS.⁴³ However a trend of increased ARDS in the patients receiving INTERCEPT processed platelets remained. A post-marketing study (known as “PIPER”, a Phase IV study of INTERCEPT Platelets Entering Routine use) was conducted to evaluate the incidence of acute lung injury, with an emphasis on ARDS (results described in section on Post-Marketing Studies).⁶⁴

Another randomized, double-blind, controlled, parallel-group trial was conducted to evaluate the efficacy and safety of apheresis INTERCEPT processed platelets prepared with the commercial INTERCEPT system compared to conventional apheresis PCs. A total of 43 adult hematology-oncology patients with hypoplastic thrombocytopenia (22 Test, 21 Reference) were enrolled at 3 study centers. INTERCEPT treatment was used in place of gamma irradiation for 93% of INTERCEPT PCs for prevention of TA-GVHD. A total of 218 platelet components were transfused (103 Test and 115 Reference). The primary endpoint was the 1-hour platelet count increment. There was no excess treatment related morbidity reported among patients supported with INTERCEPT processed platelet components.

A single-arm, open label safety study of 560 INTERCEPT processed platelet transfusions in 51 adult patients with malignant hematology-oncology disorders, including HSCT was conducted to assess the frequency of acute transfusion reactions.³⁸ Platelet concentrates were prepared from either apheresis collections or whole blood derived buffy coat platelets, treated with INTERCEPT in place of gamma irradiation, and stored up to 5 days

prior to transfusion. The frequency of acute transfusion reactions was 1.6%. This study was small in size and uncontrolled therefore the rate of acute transfusion reactions cannot be compared with that for conventional platelets.

A single-arm, open label observational study to assess acute transfusion reactions using apheresis “double unit” collections ($5-6 \times 10^{11}$) without gamma irradiation and stored up to 5 days was conducted in 46 adult hematology patients with malignant disorders, including HSCT.³⁹ A total of 551 INTERCEPT processed platelet transfusions were administered in a Swiss Red Cross blood center. The frequency of acute transfusion reactions was 2%. This study was small in size and uncontrolled therefore the rate of acute transfusion reactions cannot be compared with that for conventional platelets.

Post-Marketing Studies

A prospective, open label, single arm, treatment use study of patient safety following transfusion of INTERCEPT platelet components (aka TRUE study) was conducted as a treatment use study (Study CLI 00108). The primary objective was to provide access to INTERCEPT PCs for patients who might be at risk of transfusion-transmitted infection (TTI) due to Chikungunya virus (CHIKV) and Dengue virus (DENV) in regions in which a substantial proportion of the population has been infected or is at risk of infection by these pathogens, and in which the risk of asymptomatic infection among qualified blood donors was recognized. The study was conducted in Puerto Rico, due to the acuity and severity of the CHIKV outbreak, and was designed to include patients with serious diseases expected to require multiple transfusions of PC.

Ninety patients (55.6% male, mean age 67.2 y) were transfused with 256 INTERCEPT PCs (2.8 ± 3.5 /patient). The vast majority of the patients were hematology oncology patients (76.7%). Most patients (81.1%) received 1 transfusion cycle (transfusion support ≤ 5 days between transfusions) with 2 INTERCEPT PCs (40.0%), while 32.2% received 1 INTERCEPT PC, and 25.6% received between 3-10 INTERCEPT PCs. Mean duration of platelet support was 14.7 days. Forty-eight AEs were reported in 26 patients. Nineteen patients (21.1%) had SAEs (including 17 deaths [18.9%]). Two febrile non-haemolytic reactions and one allergic transfusion reaction were reported. No suspected cases of CHIKV or DENV infections or other TTIs were reported. Reported AEs were within the expected spectrum of co-morbidity and mortality for patients of similar age with advanced hematology-oncology diseases.

There were a total of 48 treatment emergent adverse events reported in 26 patients. Nineteen patients experienced 30 treatment emergent serious adverse events (SAE). There were 3 non-serious, non-severe Transfusion Reactions (TR) reported in the safety population (N=90).

In addition, 18 non-severe, non-serious and adverse events were reported: positive human immunodeficiency virus test result, low blood pressure, decreased blood pressure, ecchymosis, uncontrolled high blood pressure, convulsion, malaise, hydro pneumothorax, anxiety, neutropenic fever, and neutropenic fever. Three transfusion reactions (TRs) were reported, that were not part of the 18 non-related (or non-TR), non-serious, non-severe treatment-emergent adverse events. No transfusion-related acute lung injury (TRALI), no transfusion associated circulatory overload (TACO), no TA-GVHD, no hemorrhage, and no transfusion related deaths were reported following transfusion of INTERCEPT PCs during this study. None of the INTERCEPT PCs administered during the reporting period were gamma irradiated but were administered to immune compromised patients at risk for TA-GVHD.

Safety data were obtained from hemovigilance (HV) programs in routine use without patient selection: the Cerus hemovigilance program and the regulatory surveillance programs in France and in Switzerland.⁴⁴⁻⁵⁷

The populations monitored in the Cerus hemovigilance studies (CLI-HV 00045 (HV3), CLI-HV 00047 (HV1), and CLI-HV 00048 (HV2)) included 4,067 patients, where 62 patients were under the age of 1 year and 185 patients were 1-18 years of age. 50% of the patients enrolled in these studies were hematology-oncology patients, of which 12% were HSCT patients. Adverse events within 24 hours and serious adverse events within 7 days of platelet transfusion were reported. The frequencies of adverse events attributed to INTERCEPT processed platelet transfusions were not increased compared to conventional platelet transfusions reported in European regulatory hemovigilance programs.

In compliance with the FDA approval of the INTERCEPT Blood System for Platelets, a prospective, open-label, controlled, non-randomized, non-inferiority Phase IV study (PIPER study) was conducted at 15 clinical sites using a sequential cohort design with a Control cohort (n=1223) that received conventional apheresis PCs and a Test cohort (n=1068) that received apheresis INTERCEPT PCs for up to 21 days of platelet transfusion support. Patients were stratified and balanced by type of primary disease therapy. The primary outcome was the proportion of patients requiring treatment-emergent assisted mechanical ventilation (TEAMV) as a clinical indicator of acute lung injury. Results of the PIPER study showed that the Test cohort was non-inferior to the Control cohort with respect to TEAMV.⁶⁴

Clinical Experience with Transfusion of INTERCEPT Platelets Suspended in 100% Plasma

Cerus conducted an analysis of the CLI-HV 00079 study to support the current PMA supplement for the use of the INTERCEPT Blood System for platelets suspended in 100% plasma. The final report (CLI-HV 00079-2) included data for 502 INTERCEPT platelet components suspended in 100% plasma. This study was an observational safety study to detect adverse events (AEs) that if imputed as related to the transfusion were classified as transfusion reactions (TR). Adverse events related to failure of hemostasis in thrombocytopenic patients could be reported in this study. Five hundred and two INTERCEPT platelet components were administered to 169 patients. All patients received INTERCEPT platelet components for hematology-oncology related diseases including HSCT (99.4%) or surgery (0.6%).

AEs were observed following transfusion of 5 INTERCEPT components (1.0%) in 4 patients (2.4%). No AEs were classified as “serious” (SAE) following transfusion of INTERCEPT PC. No adverse events related to bleeding or hemostatic failure were reported. The 4 patients who suffered an AE experienced chills (2 patients, 1.2%), pain (1 patient, 0.6%), pyrexia (3 patients, 1.8%) and rash (1 patient, 0.6%). Based on a clinical causality assessment, these AEs were classified as febrile non-hemolytic transfusion reactions with expected signs and symptoms (pyrexia and rash), and HLA antibody associated with lower back pain. The patients recovered from these adverse events on the day of transfusion, no transfusions were interrupted due to any AE or transfusion reaction, and no patients died during the study. The types of AEs were representative of the types of events experienced by patients with transfusion-dependent thrombocytopenia and were consistent with the types of events commonly experienced by patients following transfusion of conventional platelet components according to published data and national hemovigilance programs. No transfusion related acute lung injury (TRALI), transfusion-related sepsis (TRS), or transfusion-associated graft versus host disease (TA-GVHD) were reported. The frequencies of these AEs were comparable to historical data for conventional PCs 100% plasma.^{44-57, 62} Transfusions of INTERCEPT PCs were well tolerated during this observational study, and the study provides further clinical data to support the use of the INTERCEPT Blood System with platelets suspended in 100% plasma.

ANSM and Swissmedic Active HV Programs (France and Switzerland)

Since 2009, INTERCEPT processed platelets suspended in PAS-3 (InterSol™) have been monitored in comparison to other types of platelet concentrates (suspended in PAS-3 or in 100% plasma) transfused in France through national hemovigilance program.⁴⁸⁻⁵⁷ In Switzerland, INTERCEPT processed platelets were phased into routine use during 2011, accounting for approximately 80% of all platelet concentrates transfused that year, and 100% of platelets produced thereafter, and were monitored through national hemovigilance program⁵⁶⁻⁶¹.

The number of TRALI reported to the French and Swiss HV systems during the years 2009-2013 is small, and the TRALI rates were similar in both groups. There were 6/187,142 TRALI cases per INTERCEPT processed platelet transfusions, for a TRALI rate of 0.33 per 10,000 platelet transfusion, compared to 37/1,109,135 TRALI cases per conventional platelet transfusions, for a rate of 0.32 per 10,000 platelet transfusions. Following 2013, the French hemovigilance reports no longer reported conventional and INTERCEPT platelets adverse events results separately, preventing TRALI analysis by component type for the later years. No septic transfusion reactions due to bacterial contamination of platelets were observed after the introduction of INTERCEPT processed platelets in either France or Switzerland between 2009 and 2015. Limitations of the hemovigilance system include data collection that was limited to only transfusion associated AEs (TRALI, TACO, TAD, etc.) as assessed by the reporter.

REFERENCES

1. Wollowitz, S, Fundamentals of the psoralen-based Helinx technology for inactivation of infectious pathogens and leukocytes in platelets and plasma. *Seminars in Hematology*, 2001. 38 (Suppl 11): p. 4-11.
2. Schmidt, MS, B Kapzrak, et al., Efficiency of the pathogen inactivation system INTERCEPT under experimental conditions. *Vox Sang*, 2011. 101(Suppl 1): p. 226.
3. Nussbaumer, W, D Allersdorfer, et al., Prevention of transfusion of platelet components contaminated with low levels of bacteria: a comparison of bacteria culture and pathogen inactivation methods. *Transfusion*, 2007. 47(7): p. 1125-33.
4. Lin, L, CV Hanson, et al., Inactivation of viruses in platelet concentrates by photochemical treatment with amotosalen and long-wavelength ultraviolet light. *Transfusion*, 2005. 45: p. 580-590.
5. Dupuis, K, D Arnold, et al., High titers of dengue virus in platelet concentrates are inactivated by amotosalen and UVA light. *Transfusion*, 2012. 52((3S)): p. 225A.
6. Tsetsarkin, KA, A Sampson-Johannes, et al., Photochemical inactivation of chikungunya virus in human apheresis platelet components by amotosalen and UVA light. *Am J Trop Med Hyg*, 2013. 88(6): p. 1163-9.
7. Sawyer, L, K Dupuis, et al., Inactivation of influenza A H5N1 and Lymphocytic Choriomeningitis virus (LCMV) by the INTERCEPT Blood System (IBS). *Transfusion*, 2008. 48(2S): p. 88A.
8. Roback, J, CMV Safety of Platelet Products: Comparison of Inactivation of INTERCEPT Blood System and Removal of Leukofiltration. *Transfusion*, 2007a. 47(S3): p. 23A.
9. Roback, J, Inactivation of Infectious CMV in Platelet Products: Comparison of Inactivation of INTERCEPT Blood System and Leukofiltration. *Blood*, 2007b. 110(11): p. 849A.
10. Jordan, CT, N Saakadze, et al., Photochemical treatment of platelet concentrates with amotosalen hydrochloride and ultraviolet A light inactivates free and latent cytomegalovirus in a murine transfusion model. *Transfusion*, 2004. 44: p. 1159-1165.
11. Lin, L, Inactivation of cytomegalovirus in platelet concentrates using Helinx™ technology. *Semin Hematol*, 2001. 38(4 Suppl 11): p. 27-33.
12. Singh, Y, L Sawyer, et al., Photochemical treatment of plasma with amotosalen and UVA light inactivates pathogens while retaining coagulation function. *Transfusion*, 2006. 46: p. 1168-1177.
13. Pinna, D, A Sampson-Johannes, et al., Amotosalen photochemical inactivation of severe acute respiratory syndrome coronavirus in human platelet concentrates. *Transfus Med*, 2005. 15(4): p. 269-76.

14. Steiert, M and A Brussels, Evaluation of viral and bacterial inactivation in platelet concentrates suspended in 100% plasma treated with the INTERCEPT Blood System. *Vox Sang*, 2008. 95(Suppl 1): p. 301.
15. Lin, L, R Dikeman, et al., Photochemical treatment of platelet concentrates with amotosalen and UVA inactivates a broad spectrum of pathogenic bacteria. *Transfusion*, 2004. 44: p. 1496 - 1504.
16. Sawyer, L, C Kodner, et al., Inactivation of transfusion-transmitted vector-borne pathogens. *Vox Sang*, 2009. 96(S1): p. 233.
17. Stramer, SL, FB Hollinger, et al., Emerging infectious disease agents and their potential threat to transfusion safety. *Transfusion*, 2009. 49(August 2009 Supplement): p. 1S - 29S.
18. Grellier, P, J Benach, et al., Photochemical inactivation with amotosalen and long-wavelength ultraviolet light of Plasmodium and Babesia in platelet and plasma components. *Transfusion*, 2008. 48: p. 1676-1684.
19. Van Voorhis, WC, LK Barrett, et al., Trypanosoma cruzi inactivation in human platelet concentrates and plasma by a psoralen (amotosalen HCl) and long-wavelength UV. *Antimicrob Agents Chemother*, 2003. 47(2): p. 475-9.
20. Eastman, RT, LK Barrett, et al., Leishmania inactivation in human pheresis platelets by a psoralen (amotosalen HCl) and long-wavelength ultraviolet irradiation. *Transfusion*, 2005. 45(9): p. 1459-63.
21. AABB, Standards for Blood Banks and Transfusion Services, in Process Control 2014, AABB: Bethesda, MD
22. Corash, L and L Lin, Novel processes for inactivation of leukocytes to prevent transfusion-associated graft-versus-host disease. *Bone Marrow Transplantation*, 2004. 33: p. 1-7.
23. Lin, L, L Corash, et al., Protection against TA-GVHD due to platelet transfusion by using pathogen inactivation with the INTERCEPT Blood System: gamma irradiation is not the only answer. *Haematologica*, 2010. 95 (Suppl 1): p. 230-237.
24. Hei, DJ, J Grass, et al., Elimination of cytokine production in stored platelet concentrate aliquots by photochemical treatment with psoralen plus ultraviolet A light. *Transfusion*, 1999. 39: p. 239-48.
25. Grass, JA, DJ Hei, et al., Inactivation of leukocytes in platelet concentrates by psoralen plus UVA. *Blood*, 1998. 91: p. 2180-88.
26. Luban, NL, D Drothler, et al., Irradiation of platelet components: inhibition of lymphocyte proliferation assessed by limiting-dilution analysis. *Transfusion*, 2000. 40(3): p. 348-52.
27. Pelszynski, MM, G Moroff, et al., Effect of gamma irradiation on T-cell inactivation as assessed by limiting dilution analysis: Implications for preventing transfusion associated graft vs. host disease. *Blood*, 1994. 83: p. 1683-1689.
28. Snyder, E, J McCullough, et al., Clinical safety of platelets photochemically treated with amotosalen HCl and ultraviolet A light for pathogen inactivation: the SPRINT trial. *Transfusion*, 2005. 45(12): p. 1864-75.
29. Ciaravino, V, T McCullough, et al., The role of toxicology assessment in transfusion medicine. *Transfusion*, 2003. 43: p. 1481-1492.
30. Ciaravino, V, T McCullough, et al., Pharmacokinetic and toxicology assessment of INTERCEPT (S-59 AND UVA treated) platelets. *Human and Experimental Toxicology*, 2001. 20: p. 533-550.
31. Ciaravino, V, J Hannover, et al., Assessment of safety in neonates for transfusion of platelets and plasma prepared with amotosalen photochemical pathogen inactivation treatment by a one-month intravenous toxicity study. *Transfusion*, 2009. 49: p. 985-994.
32. Tice, RR, D Gatehouse, et al., The pathogen reduction treatment of platelets with S-59 HCl (Amotosalen) plus ultraviolet A light: genotoxicity profile and hazard assessment. *Mutation Research*, 2007. 630(1-2): p. 50-68.
33. Snyder, E, T Raife, et al., Recovery and Lifespan of 111 Indium radiolabeled platelets treated with pathogen inactivation using amotosalen HCl (S-59) and UVA light. *Transfusion*, 2004. 44: p. 1732-1440.
34. Corash, L, V Paton, et al., S-59 clearance and kinetics after transfusion of platelets treated with Helinx™ Technology. *Transfusion*, 2000. 40(S10): p. 137.
35. McCullough, J, DH Vesole, et al., Therapeutic efficacy and safety of platelets treated with a photochemical process for pathogen inactivation: the SPRINT Trial. *Blood*, 2004. 104(5): p. 1534-41.

36. Murphy, S, E Snyder et al. Platelet dose consistency and its effect on the number of platelet transfusions for support of thrombocytopenia: an analysis of the SPRINT trial of platelets photochemically treated with amotosalen HCl and ultraviolet A light. *Transfusion*, 2006. 46(1):p. 24-33.
37. Janetzko, K, JP Cazenave, et al., Therapeutic efficacy and safety of photochemically treated apheresis platelets processed with an optimized integrated set. *Transfusion*, 2005. 45(9): p. 1443-1452.
38. Schlenke, P, W Hagenah, et al., Safety and clinical efficacy of platelet components prepared with pathogen inactivation in routine use for thrombocytopenic patients. *Ann Hematol*, 2011. 90(12): p. 1457-65.
39. Infanti, L, C Stebler, et al., Pathogen-inactivation of platelet components with the INTERCEPT Blood System : a cohort study. *Transfus Apher Sci*, 2011. 45(2): p. 175-81.
40. van Rhenen D J, H Gulliksson, et al., Transfusion of pooled buffy coat platelet components prepared with photochemical pathogen inactivation treatment: the euroSPRITE trial. *Blood*, 2003. 101: p. 2426-2433.
41. Slichter, SJ, RM Kaufman, et al., Dose of prophylactic platelet transfusions and prevention of hemorrhage. *N Engl J Med*, 2010. 362: p. 600-613.
42. Sigle, JP, L Infanti, et al., Comparison of transfusion efficacy of amotosalen-based pathogen-reduced platelet components and gamma-irradiated platelet components. *Transfusion*, 2013. 53(8): p. 1788-97.
43. Corash, L, JS Lin, et al., Determination of acute lung injury following repeated platelet transfusions. *Blood*, 2011. 117(3): p. 1014-1020.
44. Osselaer, JC, JP Cazenave, et al., An active haemovigilance programme characterizing the safety profile of 7437 platelet transfusions prepared with amotosalen photochemical treatment. *Vox Sang*, 2008. 94(4): p. 315-23.
45. Osselaer, JC, N Messe, et al., A prospective observational cohort safety study of 5106 platelet transfusions with components prepared with photochemical pathogen inactivation treatment. *Transfusion*, 2008. 48(6): p. 1061-71.
46. Osselaer, JC, C Doyen, et al., Universal adoption of pathogen inactivation of platelet components: impact on platelet and red blood cell component use. *Transfusion*, 2009. 49(7): p. 1412-22.
47. Cazenave, JP, H Isola, et al., Use of additive solutions and pathogen inactivation treatment of platelet components in a regional blood center: impact on patient outcomes and component utilization during a 3-year period. *Transfusion*, 2011. 51(3): p. 622-9.
48. Cazenave, JP, H Isola, et al., Pathogen Inactivation of Platelets, in *Platelet Transfusion Therapy*, J.D. Sweeney and M. Lozano, Editors. 2013, AABB Press: Bethesda, MD. p. 119-176.
49. Agence Francaise de Securite Sanitaire des Produits de Sante, Rapport Annuel Hemovigilance, in *Rapport Annuel Hemovigilance 2009*.
50. Agence Francaise de Securite Sanitaire des Produits de Sante, Rapport Annuel Hemovigilance, in *Rapport Annuel Hemovigilance 2010*.
51. Agence Francaise de Securite Sanitaire des Produits de Sante, Rapport Annuel Hemovigilance, in *Rapport Annuel Hemovigilance 2011*.
52. Agence Francais de Securite Sanitaire des Produits de Sante, Rapport Annuel Hemovigilance, in *Rapport Annuel Hemovigilance 2012*.
53. Agence Francais de Securite Sanitaire des Produits de Sante, Report Annuel Hemovigilance, in *Report Annuel Hemovigilance 2013*.
54. Agence Francais de Securite Sanitaire des Produits de Sante, Report Annuel Hemovigilance, in *Report Annuel Hemovigilance 2014*.
55. Agence Francais de Securite Sanitaire des Produits de Sante, Report Annuel Hemovigilance, in *Report Annuel Hemovigilance 2015*.
56. Swissmedic, Haemovigilance Annual Report, 2010.
57. Swissmedic, Haemovigilance Annual Report, 2011.
58. Swissmedic, Haemovigilance Annual Report, 2012.
59. Swissmedic, Haemovigilance Annual Report. 2013.
60. Swissmedic, Haemovigilance Annual Report. 2014.

61. Swissmedic, Haemovigilance Annual Report. 2015.
62. Cohn, CS, Stubbs, J, et al., A comparison of adverse reaction rates for PAS C versus plasma platelet units. *Transfusion* 2014;54:1927-34
63. Ranieri, VM, GD Rubenfeld, et al., Acute Respiratory Distress Syndrome (ARDS) - The Berlin Definition. *JAMA*, 2012. 307(23): p. 2526-2533.
64. Snyder, EL, et al., Comparative risk of pulmonary adverse events with transfusion of pathogen reduced and conventional platelet components. *Transfusion*, 2022. 62(7): p. 1365-1376.
65. Slichter, SJ, TJ Raife, et al., Platelets photochemically treated with amotosalen HCl and ultraviolet A light correct prolonged bleeding times in thrombocytopenic patients. *Transfusion*, 2006. 46: p. 731-740.

Manufactured for:

Cerus Corporation
1220 Concord Avenue,
Concord, CA 94520 USA

Cerus, INTERCEPT, and INTERCEPT Blood System are trademarks of Cerus Corporation